

## Care and Maintenance

Care and maintenance are important factors in ensuring that Allgood Hardware maintains the high quality finish for many years to come, and that working components give trouble-free operation. The frequency of maintenance will depend on the amount of use.

### Fixings

All Allgood Hardware items are fixed using Pozidriv/Supadriv screws and the correct screwdrivers must be used. Ask for Allgood Hardware XX5321/2/3 drivers. Do not use Phillips drivers as they are not compatible.

## Contents

- Care and maintenance
- Introduction
- Concealed Newton Bearing hinges
  - For timber doors
  - For metal doors
  - Power transfer hinges (for use with access control equipment or electromagnetic door controls)
  - Fixing instructions for power transfer hinges
- Rising and falling butt hinges
- Butterfly butt hinges
- Pivot set and emergency release door stop

Allgood Hardware hinges, where specified correctly to the recommendations of BS EN 1935, are capable of withstanding a severe degree of use. Most are particularly suitable for use with door closers and will help to ensure the smooth operation of the door. The range includes rising and falling hinges suitable for bathrooms and toilet cubicles and a series of hinges designed specifically for fire doors. In addition, many are suitable for metal doors and frames.

CE marking of these products for their use on fire and escape doors is required (see Standards for Architectural Hardware).

Many Allgood Hardware hinges incorporate the new fully concealed Newton Bearings. They never stick or seize, are totally corrosion proof and, with the factory applied Teflon lubricant, are **entirely maintenance-free**.

All stainless steel items are supplied with stainless steel screws for fixing to timber as standard. Fixings for metal doors/frames are provided with the appropriate metal pattern hinges.

### Tolerances

Positional tolerances of holes are +/- 0.1mm. All other tolerances are subject to a production tolerance of +/- 0.5mm.

### Handing

The following hinges are handed. The correct handing should be ascertained using the drawing below, and stated at the ordering stage (e.g. 8025L or 8025R).

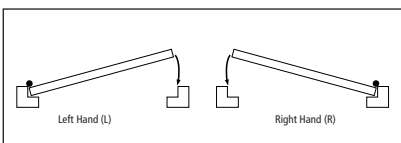

8025L/R, 8026L/R, 8066CT2L/R, 8066CT8L/R

### Standards and Performance

Most hinges are suitable for fire doors, are Certifire approved, CE marked and conform to BS EN 1935 and the requirements of PSA MOB. Allgood hinges are tested with the fixings supplied. Any substitution of these fixings may affect ultimate performance.

All CB hinges are guaranteed for 25 years.

### Hinge choice and fixing position

It is recommended that three hinges be used on all doors. On heavy doors the load is eventually borne by the three hinges. On light doors the centre hinge reduces warping and whip. The top hinge resists most of the bending forces which result from the door width (the leaf tends to pull away from the frame at the top and towards the frame at the bottom).

Where doors are not expected to warp, it is advantageous to position the middle hinge closer to the top one, typically 200mm below. Doors of height above 2100mm should have four hinges per leaf. Again, equal spacing gives maximum resistance to warping and two high and two low gives the best load carrying ability.

### Recommended hinge loadings

For most CB hinges, the maximum recommended load has increased by over 30% to 160kg for doors up to 925mm wide.

It is rare for a newly hung door to have its weight evenly distributed between the hinges. It is more likely that the load will be borne by one hinge which then settles to the point that the next hinge takes a share of the load until eventually all the hinges share the load equally.

Because, initially, all the load is on one hinge, they are rated as a single item, the total weight of the door being equal to the rated loading.

For doors fitted with backcheck door closers, BS EN 1935 recommends that the actual door mass should be increased by 50% when selecting the hinge, due to the extra forces directed onto the hinges when the door reaches the backcheck position. However, Allgood Hardware hinges have undergone successful testing through five million cycles, with the backcheck operated on every cycle and, as Allgood warrant their hinges, there is no need to make the BS recommended allowance.



### Maximum door mass/BS EN Grade

40kg/7	60kg/10	80kg/11	100kg/12	120kg/13	160kg/14
8075		48293	8075BB	8067CB	8064CB
8026	8025				8066CB
					8068CB
					8080CB
					8081CB

As door width increases so do the bending forces on the top hinge. For this reason the recommended loading is reduced to accommodate this extra mass. Hinges should be set into accurate mortises to avoid hinge bind. They should also be fitted exactly vertical and in alignment with each other.

### Door width (mm) Reduction in load capacity

926–1050	10%
1051–1150	20%
1151–1250	30%

### Door weight chart (weight, in Kg, per m<sup>2</sup>)

Thickness (mm)	35	45	55	65
Hollow core	10	10	10	10
Pine	14.5	16	17	21
Mahogany	22	25	28	35.5
Oak	30	34	37.5	46
Hollow metal	33	33	33	33

8064CB

Concealed twin Newton Bearing butt hinges for doors up to 160kg, pair.

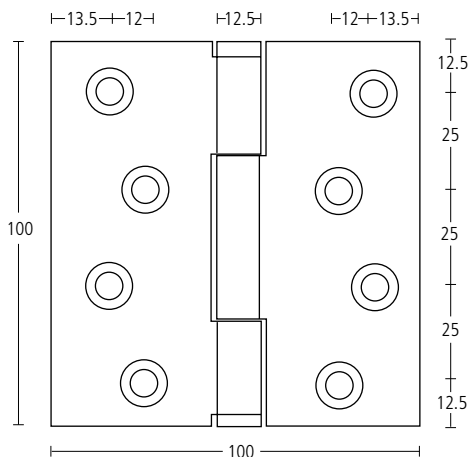
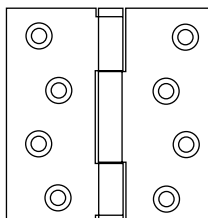

- 100 x 100 x 3mm
- Triple knuckle
- Twin concealed Newton Bearings
- Button tipped
- Jig drilled
- Grade 316 stainless steel
- Maintenance free
- Totally corrosion proof
- Smoother action than ball bearings
- Load bearing capacity to 160kg
- Certifire approved
- Satisfy test requirements to BS EN 1935 Grade 14, [4771114014](#) and is **CE** marked 1121-CPD-AC001
- Compatible with backcheck door closers, i.e. the performance rating is not reduced
- Guaranteed for 25 years
- No.12x1¼ stainless steel screws

Finishes: SS • PS • TS

Brass – XX8064CBA (full ref.)

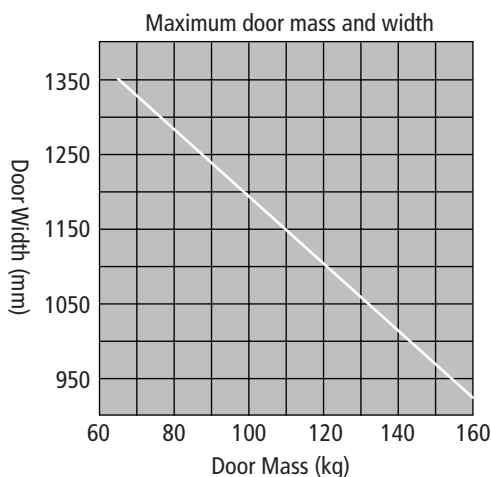

## 8066CB

Concealed twin Newton Bearing butt hinges for doors up to 160kg, pair.

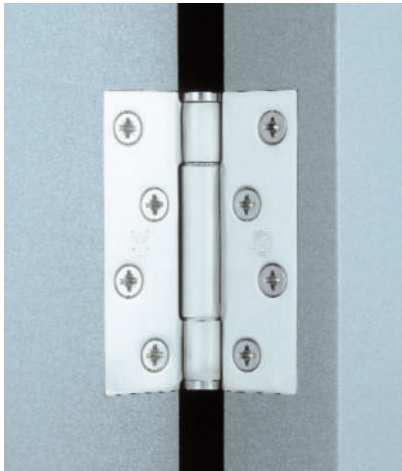

- 100 x 75 x 3mm
- Triple knuckle
- Twin concealed Newton Bearings
- Button tipped
- For easy routing 10mm radiused corners are available, suffix 'R'
- Jig drilled
- Grade 316 stainless steel
- Maintenance free
- Totally corrosion proof
- Smoother action than ball bearings
- Load bearing capacity to 160kg
- Certifire approved
- Satisfy test requirements to BS EN 1935 Grade 14, 477114014 and is **CE** marked 1121-CPD-AC001
- Finished with softened edges
- Compatible with backcheck door closers, i.e. the performance rating is not reduced
- Guaranteed for 25 years
- No.12x1¼ stainless steel screws

Finishes: SS • PS • TS

Brass – XX8066CBA (full ref.)

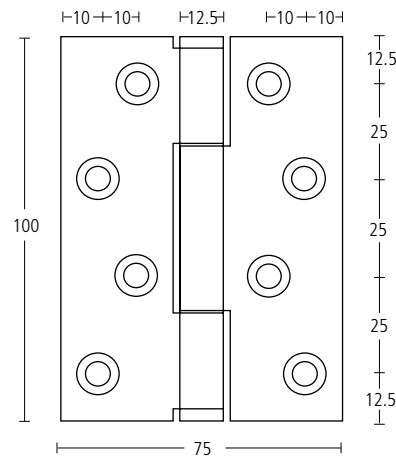

8066CB

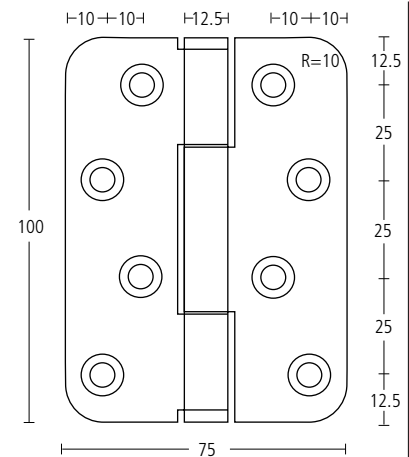

8066RCB

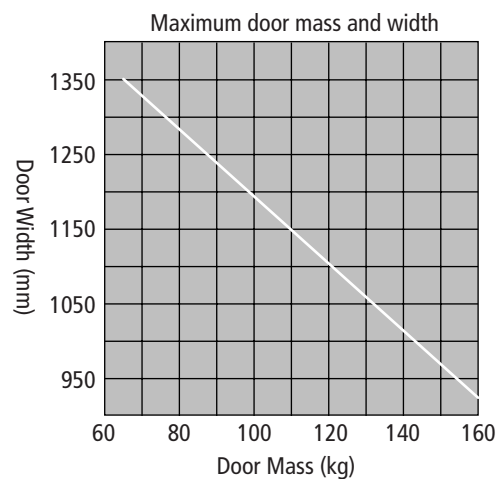

8067CB

Concealed twin Newton Bearing butt hinges for metal doors up to 120kg, pair.

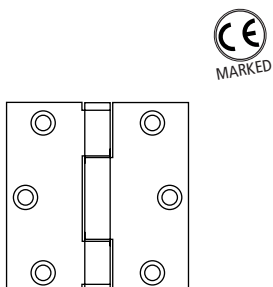

- 89 x 89 x 3mm
- Triple knuckle
- Twin concealed Newton Bearings
- Button tipped
- Template drilled to ANSI 156.7 with M6 x 12MT posidrive truncated undercut stainless steel machine screws
- Grade 316 stainless steel
- Maintenance free
- Totally corrosion proof
- Smoother action than ball bearings
- Load bearing capacity to 120kg
- Certifire approved
- Satisfy test requirements to BS EN 1935 Grade 13,  $476114013$  and is **CE** marked 1121-CPD-AC003
- Compatible with backcheck door closers, i.e. the performance rating is not reduced
- Guaranteed for 25 years

Finishes: SS • PS • TS  
 Brass – XX8067CBA (full ref.)

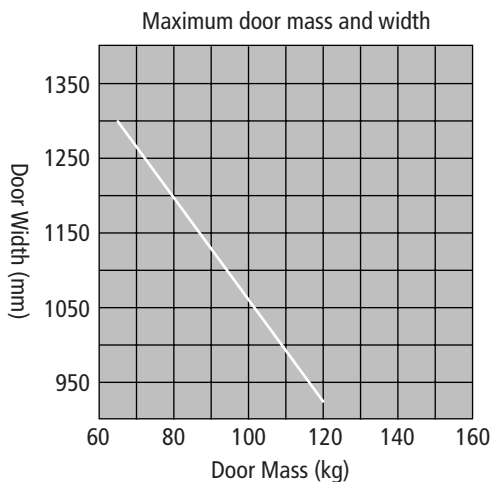
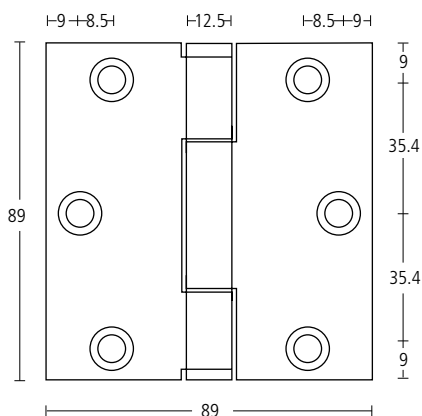

## 8068CB

Concealed twin Newton Bearing butt hinges for metal doors up to 160kg, pair.

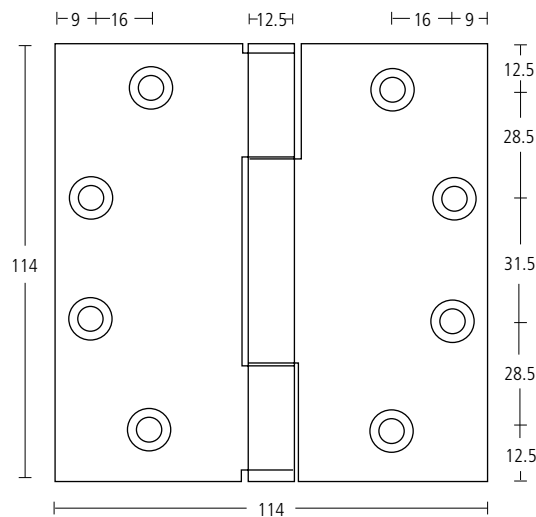
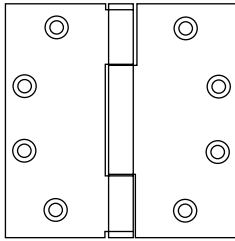

- 114 x 114 x 3mm
- Triple knuckle
- Twin concealed Newton Bearings
- Button tipped
- Template drilled to ANSI 156.7 with M6 x 12MT posidrive truncated undercut stainless steel machine screws
- Grade 316 stainless steel
- Maintenance free
- Totally corrosion proof
- Smoother action disc bearings
- Load bearing capacity to 160kg
- Certifire approved
- Satisfy test requirements to BS EN 1935 Grade 14, [4761114014](#) and is **CE** marked 1121-CPD-AC001
- Compatible with backcheck door closers, i.e. the performance rating is not reduced
- Guaranteed for 25 years

Finishes: SS • PS • TS

Brass – XX8068CBA (full ref.)

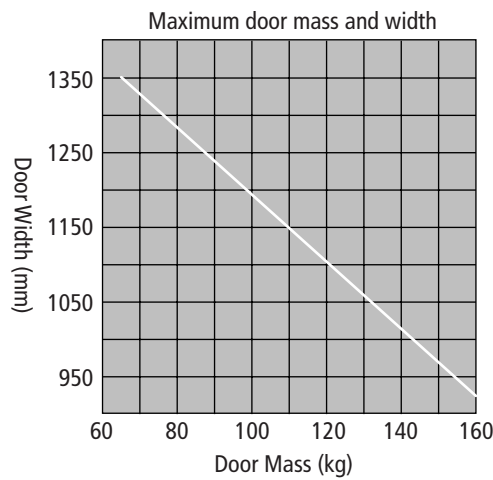

8080CB

Concealed twin Newton Bearing butt hinges for metal doors/frames up to 160kg, pair.

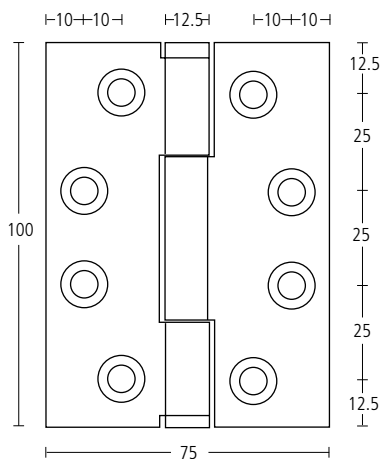
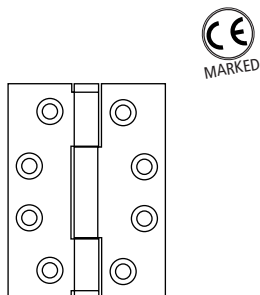

- 100 x 75 x 3mm
- Triple knuckle
- Twin concealed Newton Bearings
- Button tipped
- Jig drilled for metal doors/frames complete with M6 x 12MT posidrive truncated undercut stainless steel machine screws
- Grade 316 stainless steel
- Maintenance free
- Totally corrosion proof
- Smoother action disc bearings
- Load bearing capacity to 160kg
- Certifire approved
- Satisfy test requirements to BS EN 1935 Grade 14, [4]7[7]1[1]4[0]14 and is CE marked 1121-CPD-AC001
- Compatible with backcheck door closers, i.e. the performance rating is not reduced
- Guaranteed for 25 years

Finishes: SS • PS • TS

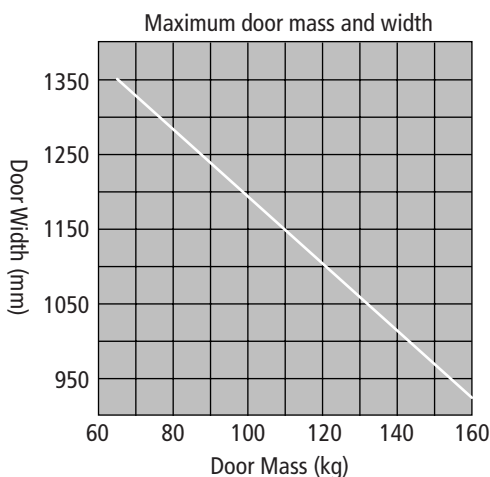

## 8081CB

Concealed twin Newton Bearing butt hinges for metal doors/frames up to 160kg, with integral security bolt, pair.

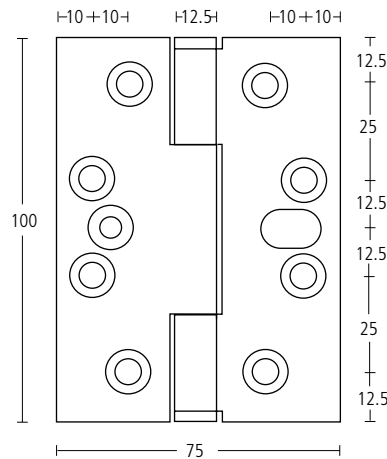
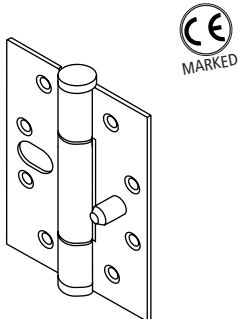

- 100 x 75 x 3mm
- Triple knuckle
- Twin concealed Newton Bearings
- Button tipped
- Jig drilled for metal doors/frames complete with M6 x 12MT posidrive truncated undercut stainless steel machine screws
- Grade 316 stainless steel
- Maintenance free
- Totally corrosion proof
- Smoother action disc bearings
- Load bearing capacity to 160kg
- Certifire approved
- Satisfy test requirements to BS EN 1935 Grade 14, 4771114114 and is **CE** marked 1121-CPD-AC002
- Finished with softened edges
- Compatible with backcheck door closers, i.e. the performance rating is not reduced
- Guaranteed for 25 years

Finishes: SS • PS • TS

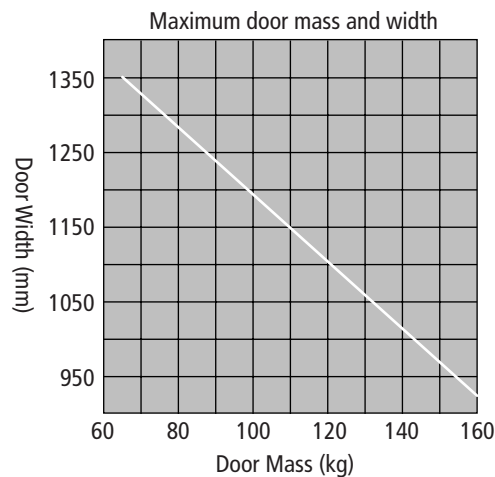

8066CT2L/R

Load bearing power transfer butt hinge with concealed Newton Bearing.  
 For doors up to 160kg, when used in conjunction with a pair of 8066CB hinges.

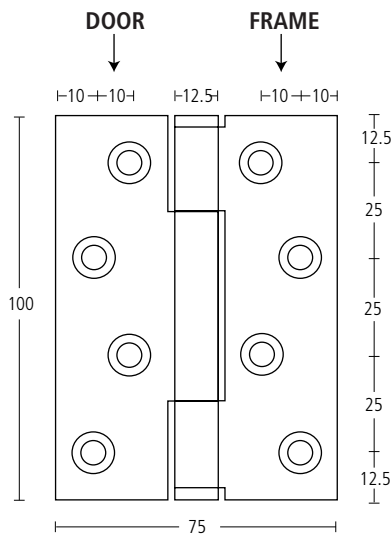
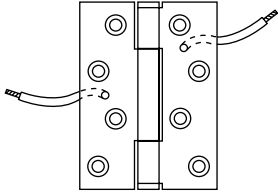

- STATE HAND (e.g. 8066CT2L or 8066CT2R – see pages xxx and xxx)
- Left hand shown, for clockwise closing doors
- Twin power conductors
- Maximum 50v/5000mA per conductor
- 152mm free tails
- 100 x 75 x 3mm
- Triple knuckle
- One Concealed Newton Bearing
- Button tipped
- Jig drilled
- Grade 316 stainless steel
- Certifire approved
- Maintenance free
- Totally corrosion proof
- Smoother action than ball bearings

Finishes: SS • PS • TS

**8066CT8L/R**

Load bearing 8 way power transfer butt hinge with concealed Newton Bearing.  
For doors up to 160kg, when used in conjunction with a pair of 8066CB hinges.

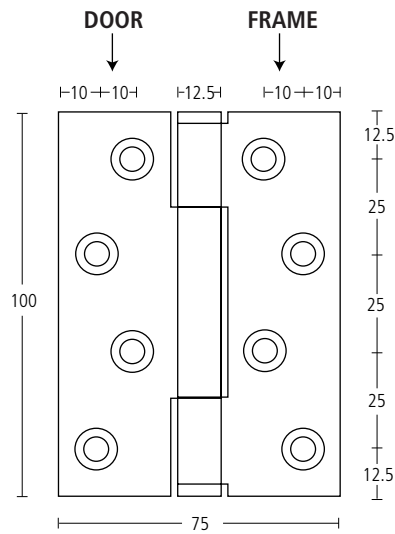
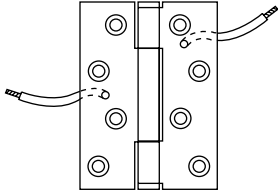

- STATE HAND (e.g. 8066CT8L or 8066CT8R – see over)
- Left hand shown, for clockwise closing doors
- 8 way power conductors
- Maximum 50v/5000mA per conductor
- 152mm free tails
- 100 x 75 x 3mm
- Triple knuckle
- One Concealed Newton Bearing
- Button tipped
- Jig drilled
- Grade 316 stainless steel
- Certifire approved
- Maintenance free
- Totally corrosion proof
- Smoother action than ball bearings

Finishes: SS • PS • TS

## Fixing Power Transfer Hinges 8066CT2/8066CT8

### Application

These hinges have integral cables which will pass a current from the frame into the door or side panel. They are suitable for use with any Allgood Secure access control equipment, or electro-magnetic door closers. The hinges are designed specifically for use with standard Allgood Hardware 8066CB hinges.

### Technical Information

Maximum voltage: 24V.

Number of conductors: 2 (8066CT2)  
8 (8066CT8).

Max. current per conductor: 5A.

Cable tails: 152mm long.

Material: Grade 316 stainless steel.

Finishes: SS & PS from stock. Other finishes to order.

Fixings: Supplied with 8 x No.12 wood screws, 8 x M6 undercut head metal thread screws.

### Handing and Positioning

- The hinges are handed and for long term durability it is essential that the correct hinge is fitted and with the TOP uppermost, as shown below.

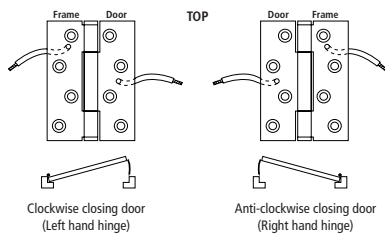

- The hinge should be fitted as the central hinge of a set of three, in a position suitable for the type of use (i.e. Option 1: access control or Option 2: door closer).

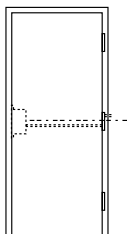

Option 1

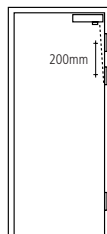

Option 2

### Fixing Instructions

- The door and frame must be prepared for the cable run to the electronic hardware items and to accept the hinge flaps in the normal way.  
Note: the cable entry hole (10mm $\varnothing$ ) in the frame should be approximately 27mm above the cable entry hole in the door.

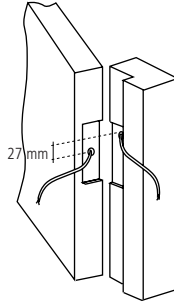

- Fix the door to the frame with the other load-bearing hinges and check that the door swings freely.
- Check that you have the correct hand of power transfer hinge (see opposite).
- Ensure that cables to the other hardware project sufficiently to make the connections. Using standard connector blocks, make all the necessary connections to the hinge from the door and from the frame. (The door and frame may need to be cut away locally to accept the connector blocks.)

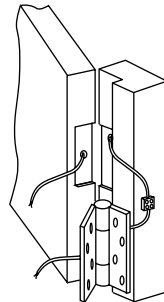

- Feed the wires back inside the door and frame and fix the hinge with the screws provided, making sure no wires are trapped behind the hinge flaps.

## 8025L/R

Rising butt hinges for doors up to 60kg, pair



- STATE HAND (e.g. 8025L or 8025R) – left hand shown
- 100 x 77 x 3mm
- Minimum door thickness 29mm
- To ensure correct working, pairs of rising butts must be fitted coaxially with screws supplied
- Only 2 butt hinges for each door
- Supplied with recommended lubricant

Finishes: SS • PS • PB

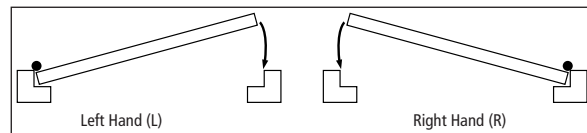
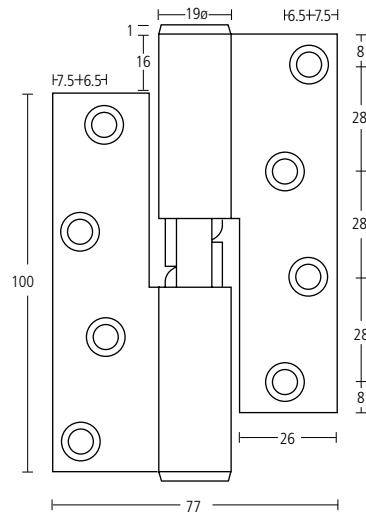

8026L/R

Falling butt hinges for doors up to 50kg, pair

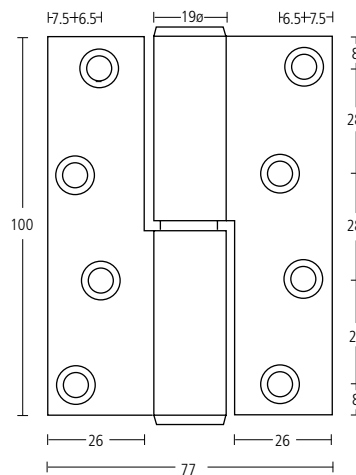
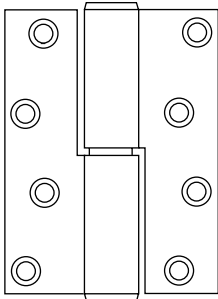

- STATE HAND (e.g. 8026L or 8026R)  
– left hand shown
- 100 x 77 x 3mm
- Maximum door opening 120°
- Minimum door thickness 29mm
- To ensure correct working, pairs of falling butts must be fitted coaxially with screws supplied
- Only two butt hinges for each door
- Supplied with recommended lubricant

Finishes: SS • PS • PB

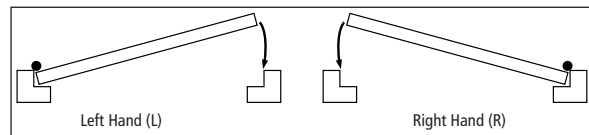

**8075BB**

Newton Bearing butt hinges for doors up to 100kg, pair.

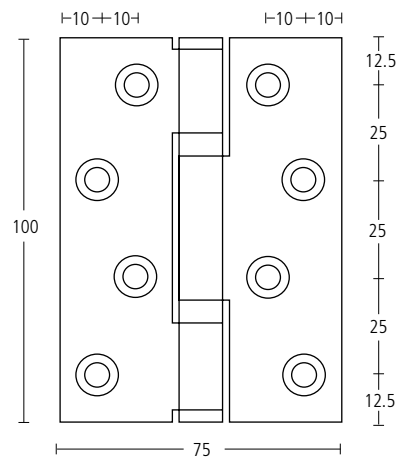
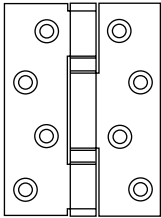

- 100 x 75 x 2.5mm
- Triple knuckle
- Twin Newton Bearings
- Button tipped
- Jig drilled
- Plated steel
- Maintenance free
- Smoother action than ball bearings
- Uprated load bearing
- These hinges have been incorporated in fire test assemblies which have achieved at least 60 minutes on timber doorsets and 240 minutes on metal doorsets
- Satisfy test requirements to BS EN 1935, Grade 12, 475114012 and is **CE** marked 1121-CPD-AC004
- All finishes have been tested by BSI and have passed 96 hour salt spray tests to BS EN 1670

Finishes – Full Product Reference

Brass – XX8075BBA

Bronze – XX8075BBB

Satin chrome – XX8075BBC

Spectra colour coated – TX8075BBD

Polished chrome – XX8075BBF

8075

Butt hinges for doors up to 40kg, pair.

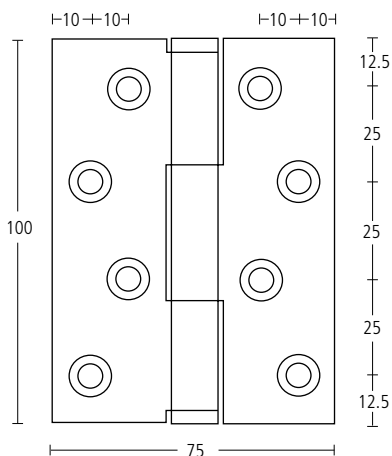
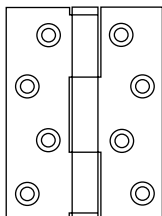

- 100 x 75 x 2.5mm
- Triple knuckle
- Button tipped
- Jig drilled
- Plated steel
- These hinges have been incorporated in fire test assemblies which have achieved at least 60 minutes on timber doorsets and 240 minutes on metal doorsets
- Satisfy test requirements to BS EN 1935, Grade 12,  $\frac{4}{7}\frac{5}{11}\frac{4}{012}$  and is  $\text{CE}$  marked 1121-CPD-AC004
- All finishes have been tested by BSI and have passed 96 hour salt spray tests to BS EN 1670. However, in use, as one knuckle rotates and bears the weight of the door on the other, the protective finish will be worn away and corrosion may take place at that point.

Finishes – Full Product Reference

- Brass – XX8075A
- Bronze – XX8075B
- Satin chrome – XX8075C
- Spectra colour coated – TX8075D
- Zinc – XX8075E
- Polished chrome – XX8075F

## 48293

Butterfly butt hinges for doors up to 80kg,  
pair.

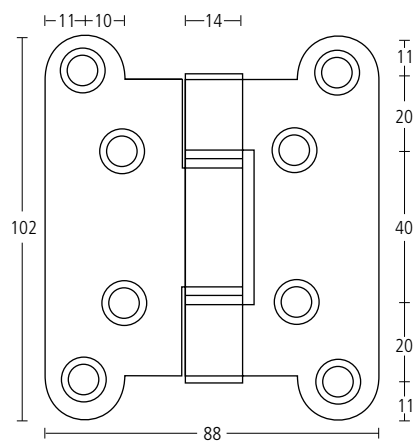
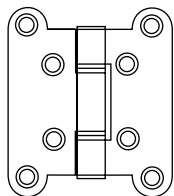

- 102 x 88 x 3mm
- Fixed pin
- Button tipped
- Drilling template supplied
- 2mm leaf gap
- Grade 304 stainless steel
- Self-lubricating bearings

Finishes: SS • PS

XX13001

Double action pivot set.  
For emergency access to toilet cubicles.

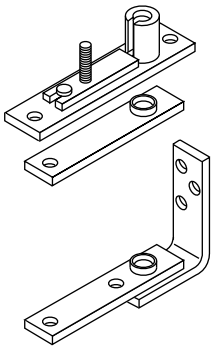

- For emergency use in hospitals, nursing homes or wherever the ill or infirm run the risk of falling over and blocking an inward opening bathroom or toilet door
- Allows the door to swing in either direction. Specifically designed for use with the XX13005 emergency release door stop
- For doors up to 44mm thick
- Bottom bracket is frame mounted but must be floor supported when used on doors weighing in excess of 30kg
- Medium duty assembly for interior doors of average frequency traffic
- For doors weighing up to 80kg and up to 1100mm wide
- Top and bottom door plates have oil impregnated bronze bearings

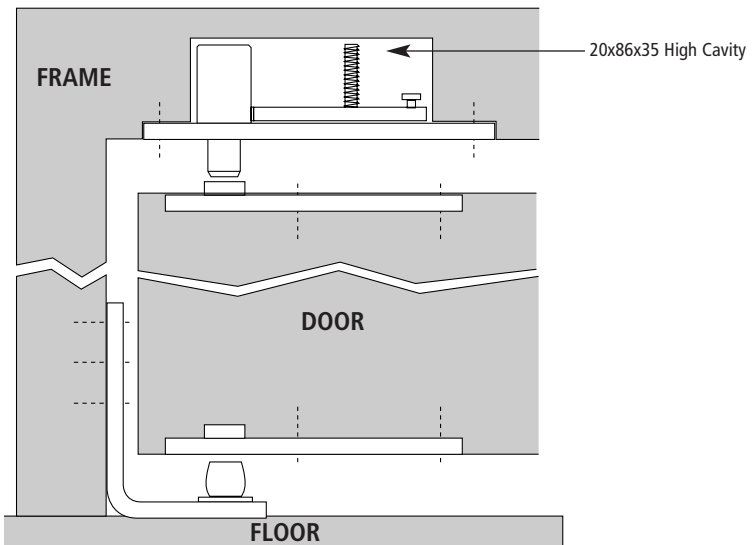
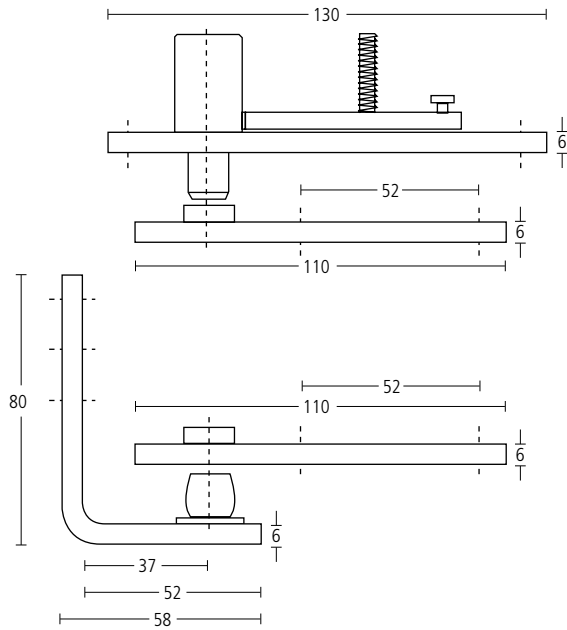

## XX13005

Emergency release door stop.  
For use in conjunction with XX13001  
double action pivot set.

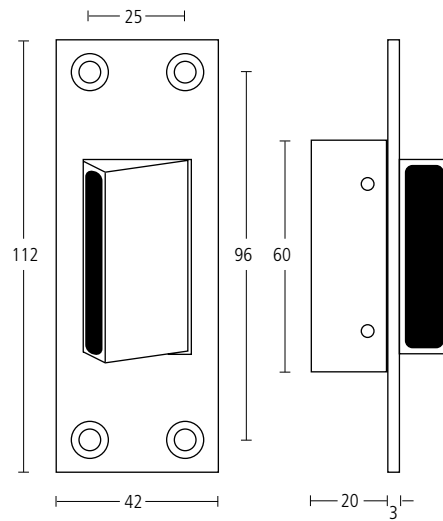
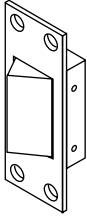

- Stainless steel
- Stop release resets automatically
- Built-in fingertip release
- Rubber insert for quieter action
- Allows double action doors to operate as single action when hung on centre pivots